

R7006SB

◆ FASSTest-2.4GHz Bidirectional Communication System / FASST(Multi-ch,7ch) -2.4GHz
◆ S.BUS2 / S.BUS Port and 6 Channels for Conventional System Receiver

Thank you for purchasing a Futaba R7006SB FASSTest-2.4GHz compatible receiver. The R7006SB receiver features bi-directional communication with a FASSTest Futaba transmitter using the S.BUS2 port. Using the S.BUS2 port an impressive array of telemetry sensors may be utilized. It also includes both standard PWM output ports (1-6ch) and S.BUS output ports. The R7006SB can also be switched the FASST(Multi-ch/7-ch) System.

● **Applicable systems: Futaba FASSTest-2.4GHz / FASST (Multi-ch,7ch) -2.4GHz system transmitter**

Usage precaution

- Analog servos cannot be used with the R7006SB in the FASSTest 12CH / FASST High-speed mode.

⚠ WARNING

- ❶ Changes or modification not especially approved by the party responsible for compliance could void the user's authority to operate the equipment.
- ❷ The R7006SB receiver should be protected from vibration by foam rubber, Velcro, or similar mounting methods. Protect from moisture.
- ❸ Keep away from conductive materials to avoid short circuits.

Antenna installation precaution

- ❶ Do not cut or bundle the receiver antenna wire.
- ❷ Do not bend the coaxial cable. It causes damage.
- ❸ The antennas must be mounted in such a way to assure they are strain relieved.
- ❹ Keep the antenna as far away from the motor, ESC and other noise sources as you possibly can.
- ❺ Be sure that the two antennas are placed at 90 degrees to each other.

■ The R7006SB has two antennas. In order to maximize signal reception and promote safe modeling Futaba has adopted a diversity antenna system. This allows the receiver to obtain RF signals on both antennas and fly problem-free.

Antenna installation for carbon fuselage

❶ You must leave 30mm at the tip of the antenna fully exposed. The exposed antenna should be secured so that it cannot move around or back inside of your aircraft.

Be careful of connector insertion

❶ Don't connect an S.BUS servo / gyro to S.BUS2 connector.

Link precaution

❶ Do not perform the linking procedure while the motor's main power connected or the engine is operating as it may result in serious injury.

❷ When the linking is complete, please cycle the receiver power and ensure the receiver is properly linked to the transmitter.

❸ Please power up your system in this order. Transmitter first, followed by the receiver.

❹ If the R7006SB receiver was previously linked to another transmitter, make sure that transmitter is not operating while linking the receiver to the new transmitter.

Compliance Information Statement (for U.S.A.)

This device, trade name Futaba Corporation, model number R7006SB, complies with part15 of the FCC Rules. Operation is subject to the following two conditions:

- (1) This device may not cause harmful interference, and
- (2) This device must accept any interference received, including interference that may cause undesired operation.
- (3) This module meets the requirements for a mobile device that may be used at separation distances of more than 20cm from human body. To meet the RF exposure requirements of the FCC this device shall not be co-located with another transmitting device.

The responsible party of this device compliance is: Futaba Service Center
3002 N Apollo Drive Suite 1, Champaign, IL 61822 U.S.A.
TEL (217)398-8970 or E-mail: support@futaba-rc.com (Support)

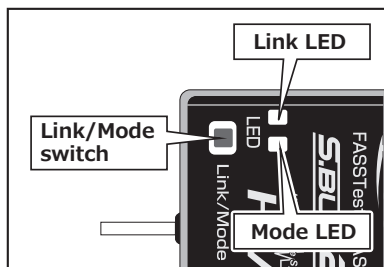
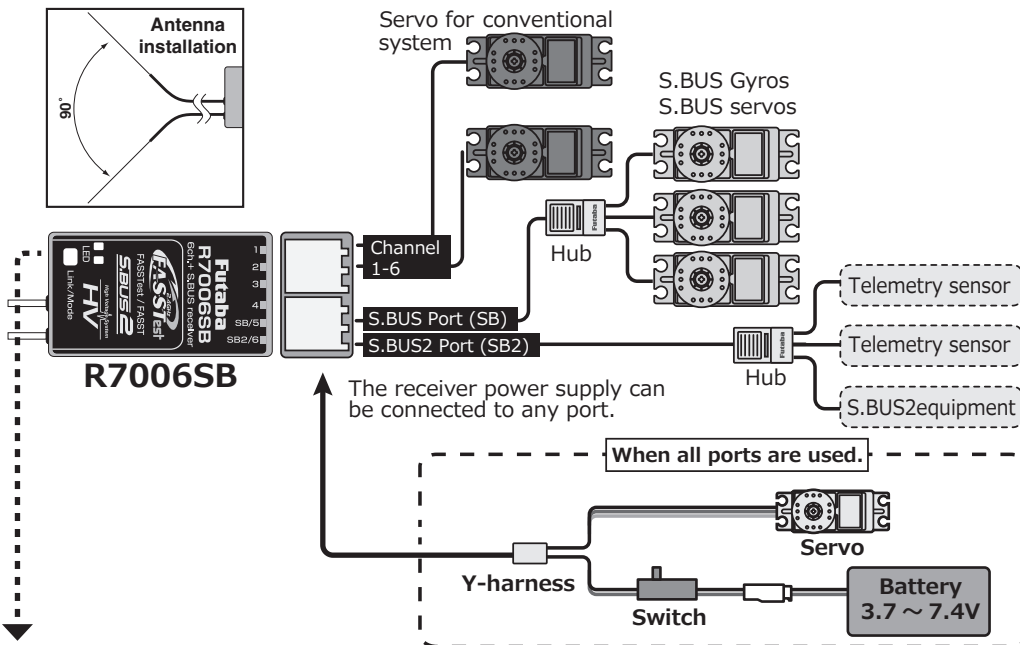

R7006SB Specifications

- FASSTest-2.4GHz system(18ch/12ch mode)
- FASST-2.4GHz system (Multi-ch/7ch mode)
- S.BUS2 and S.BUS port and 6ch for conventional system receiver
- Dual antenna diversity
- Size: 0.89 x 1.5 x 0.48 in. (22.5x38.1x12.2mm)
- Weight: 0.28 oz. (8g)
- Power requirement: 3.7V to 7.4V(Voltage range: 3.5 to 8.4V)
- Battery F/S Voltage: FASSTest---It sets up with a transmitter FASST---3.8V

LED Indication

System	Mode LED	Status	Link LED
FASSTest	Green Solid	No signal reception	Red Solid
		Receiving signals	Green Solid
		Waiting for link	Start → 2second later → Red Blink (1second)
FASST	Off	No signal reception	Red Solid
		Receiving signals	Green Solid
		Receiving signals but ID is unmatched	Green Blink
FASSTest FASST	-	Waiting for link	Red Blink
FASSTest FASST	-	Unrecoverable error (EEPROM, etc.)	Alternate blink

*When on "FASST-7ch" mode, the fail safe function can be set for 3-channel only.

*Be sure that when using ESCs regulated output the capacity of the ESC must meet your usage condition.

*Never use dry batteries for the power supply of the R7006SB as they may cause difficulties.

Channel Modes

The R7006SB is capable of changing its channel allocations as described in the table below. This is especially important when using the receiver in a dual receiver mode. See your transmitter operation manual for complete details on operating in the dual receiver mode.

- 1 Turn on the receiver. [Transmitter is always OFF]
- 2 Press and hold the Mode/Link button for 5 seconds to 10 seconds.
- 3 When the LED of the receiver changes from blinking red to blinking red with green, Mode/Link button is released.
- 4 The LED should now be blinking red in 2 times of the patterns described by the chart below.
- 5 Each press of the Mode/Link button advances the receiver to the next mode.
- 6 When you reach the mode that you wish to operate in, press and hold the Mode/Link button for more than 2 seconds. When LED blinks in green with red, it is the completion of a mode change, Mode/Link button is released.
- 7 Please cycle the receiver power off and back on again after changing the Channel mode.

R7006SB CH Mode table

Output connector	Channel			
	Mode A	Mode B	Mode C	Mode D
1	1	1	1	9
2	2	2	2	10
3	3	3	3	11
4	4	4	4	12
5/SB	5	S.BUS	6	S.BUS
6/SB2	6	S.BUS2	S.BUS2	S.BUS2
Red LED blink	1 time	2 times	3 times	4 times

Default

Systems (FASSTest ↔ FASST) change method

- 1 Turn on the receiver. [Transmitter is always OFF]
- 2 Press and hold the Link/Mode button for more than 10 seconds.
- 3 When the LED begins to blink green the button may be released.
- 4 The LED should now be blinking green in one of the patterns described by the chart below.
(Default : FASSTest)
- 5 Each press of the Mode/Link button advances the receiver to the next system.
- 6 When you reach the system that you wish to operate in, press and hold the Mode/Link button for more than 2 seconds. When LED blinks in green with red, it is the completion of a system change, Mode/Link button is released.
- 7 Please cycle the receiver power off and back on again after changing the system.

R7006SB System table

Green LED blink	System
1 time	FASSTest : Default
2 times	FASST Multi-ch Normal mode
3 times	FASST Multi-ch High-speed mode
4 times	FASST 7ch Normal mode
5 times	FASST 7ch High-speed mode

*The telemetry cannot be used with the FASST system.

本產品符合低功率電波輻射性電機管理辦法第十二條、第十四條等條文規定
 1. 經型式認證合格之低功率射頻電機，非經許可，公司、商號或使用者均不得擅自變更頻率、加大功率或變更原設計之特性及功能。
 2. 低功率射頻電機之使用不得影響飛航安全及干擾合法通信；經發現有干擾現象時，應立即停用，並改善至無干擾時方得繼續使用。前項合法通信，指依電信法規定作業之無線電通信。低功率射頻電機須忍受合法通信或工業、科學及醫療用電波輻射性電機設備之干擾。

FASSTest

FASSTest is a bidirectional communication system between the R7006SB receiver and FASSTest capable transmitters. Multiple optional telemetry sensors may be connected to the S.BUS2 on the receiver and that data is in turn displayed on the transmitter.

Link to the transmitter : FASSTest

- 1 Bring the transmitter and the receiver close to each other, within 20 inches (half meter).
- 2 Turn on the transmitter. Place the transmitter into the receiver linking mode.
- 3 Turn on the receiver.
- 4 The receiver will wait for the linking process to begin for 2 seconds. Following that it will return to the normal operation mode.
- 5 When the LED of the receiver changes from blinking red to solid green, linking is complete.
(A link waiting state is ended in 1 second.)

- Refer to the transmitters operation manual for complete details on how to place the transmitter into the linking mode.
- If there are many FASSTest systems turned on in close proximity, your receiver might have difficulty establishing a link to your transmitter. This is a rare occurrence. However, should another FASSTest transmitter/receiver be linking at the same time, your receiver could link to the wrong transmitter. This is very dangerous if you do not notice this situation. In order to avoid the problem, we strongly recommend you to double check whether your receiver is really under control by your transmitter.
- If the System Type of the transmitter is changed, the receiver will need to be re-linked to the transmitter.

S.BUS2

S.BUS2 extends S.BUS and supports bidirectional communication. Sensors are connected to the S.BUS2 port.

Link to the TMA-1 Telemetry Adapter

- 1 R7006SB has to be FASSTest.
- 2 First, a transmitter and a receiver are linked.
- 3 Transmitter is turned off.
- 4 Press and hold the Mode/Link button of R7006SB for 15 seconds.
- 5 When LED of R7006SB, Red Blink → Red with green Blink → Green Blink → Red Blink → Mode/Link button is released.
- 6 R7006SB was link mode with TMA-1. The LED blinks in green with red of R7006SB.
- 7 The link button of TMA-1 is pushed for a long time to LED blink.
- 8 Completion of a link will change LED of TMA-1 green from red only for a moment.
- 9 Please cycle the receiver power.

FASST

When switched, the R7006SB can use the FASST-Multi/7ch mode. When the FASST system is used, the telemetry cannot be used. The FASST system has a Normal mode and a High-speed mode. However, in the High-speed mode, analog servos cannot be used.

Link to the transmitter : FASST

- 1 Bring the transmitter and the receiver close to each other, within 20 inches (half meter).
 - 2 Turn on the transmitter and receiver.
 - 3 Link operation is performed by the Link/Mode switch.
- When using TM-8 module, it's possible to set F/S position (only 3CH).

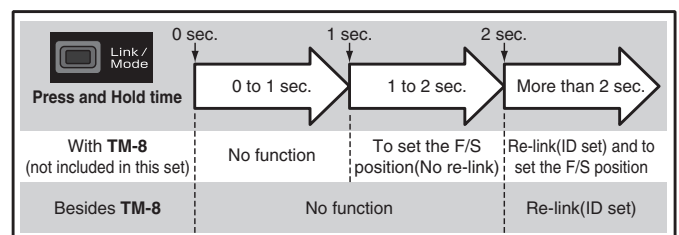

*Refer to the instruction manual of the transmitter or module used for a description of the linking operation, F/S position setting methods and other details.